

BASE UNIT

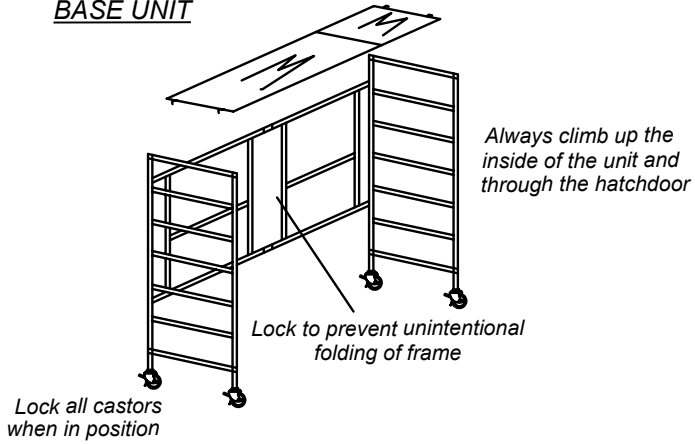

FOLDING G/RAIL SECTION OPTIONAL

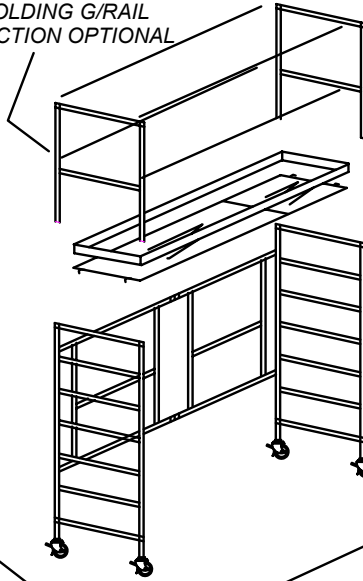

BASE UNIT WITH GUARDRAIL SECTION AND TOEBOARD

(BOTH OPTIONAL AT THIS HEIGHT)

WITH PLATFORM ON TOP RUNG IT GIVES A WORK LEVEL OF LESS THAN 2M.

2.9M PLAT HT

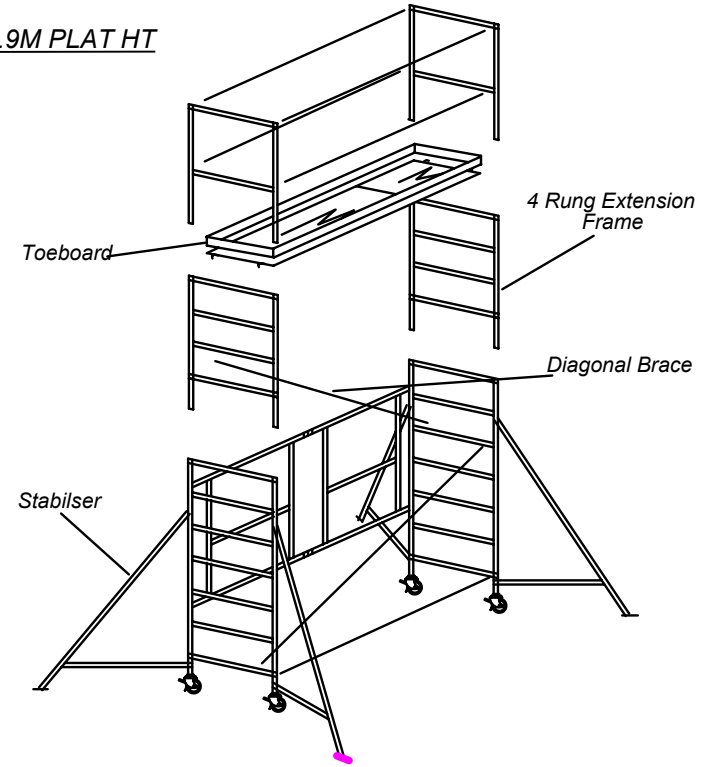

3.4 M PLAT HT

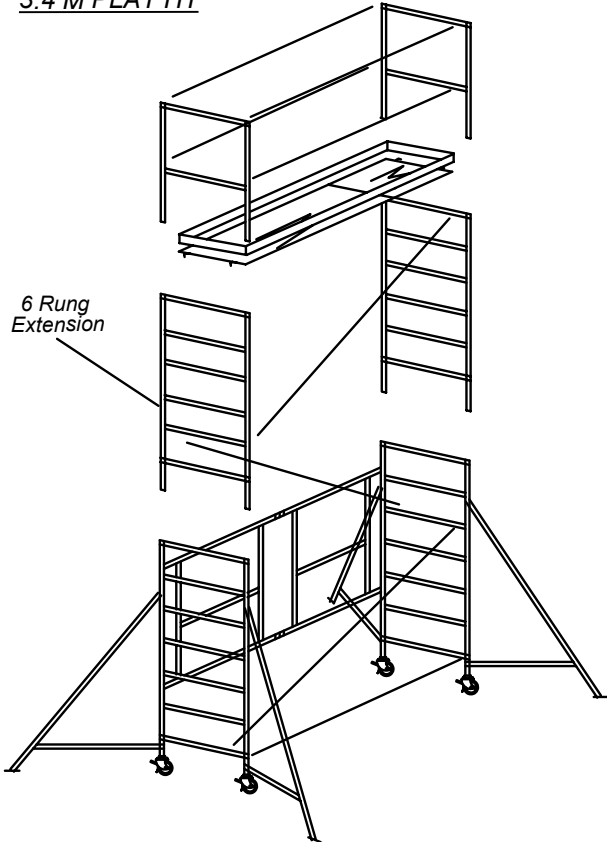

3.9 M PLAT HT

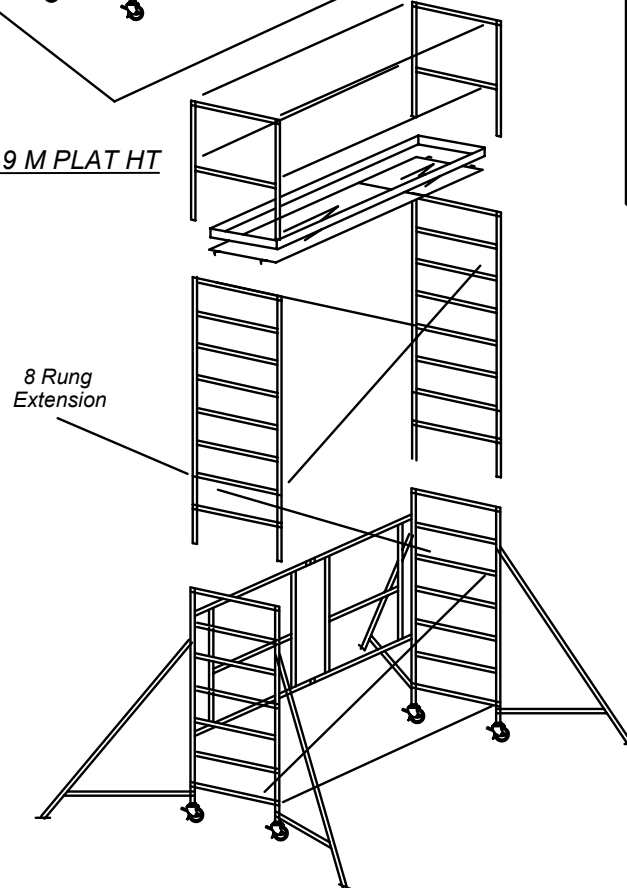

NOTES

- 1) ALWAYS LOCK CENTRAL SECTION TO PREVENT THE UNINTENTIONAL FOLDING OF FRAMES.
- 2) FIT HATCHDOOR SO THAT THE OPENING IS ON THE LADDERFRAME SIDE.
- 3) ALWAYS CLIMB UP THE INSIDE OF THE UNIT, USING THE LADDERFRAME, AND THROUGH THE HATCHDOOR OPENING.
- 4) WHEN LOCKING FRAMES TOGETHER ENSURE LOCKING CLIPS ARE FITTED CORRECTLY.
- 5) ABOVE 2M PLATFORM HEIGHT FIT A TOEBOARD AND HANDRAILS AT 0.5M & 1.0M.
- 6) REFER TO SAFETY NOTES ON REVERSE SIDE FOR MORE INFORMATION.
- 7) IF IN DOUBT ABOUT ANY APPLICATION DO NOT GUESS CONSULT YOUR SUPPLIER.

SPECIAL NOTE

Users must conduct their own risk assessment to ensure that the equipment conforms with the new Falls From Height directive. There is no lower height limit for falls from height for protection. Thus handrail and guardrails may well be required to be fitted at any height.